

Created on 1/20/2006 1:27:56 PM

**COMPUTER GENERATED DOCUMENT
MANUAL CHANGES NOT ALLOWED**

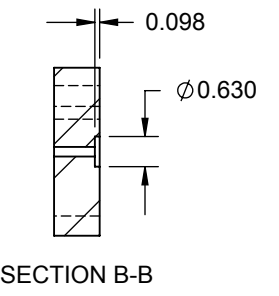
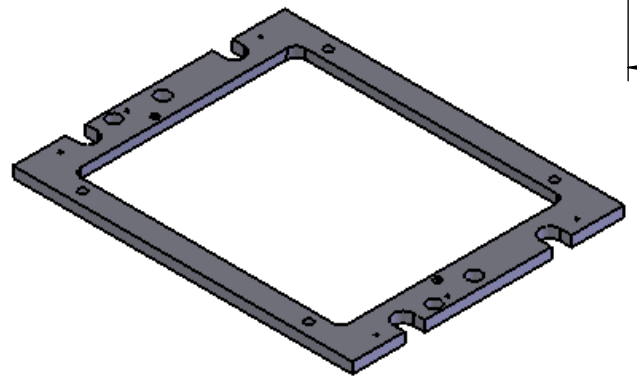
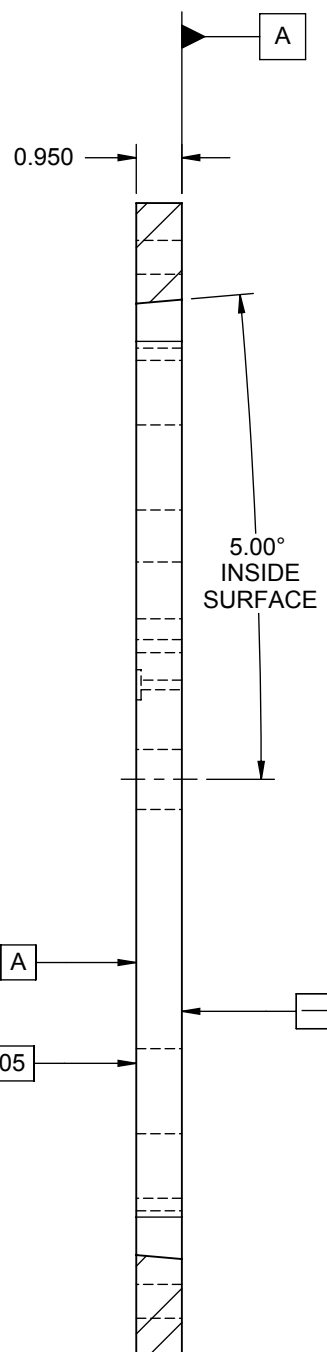
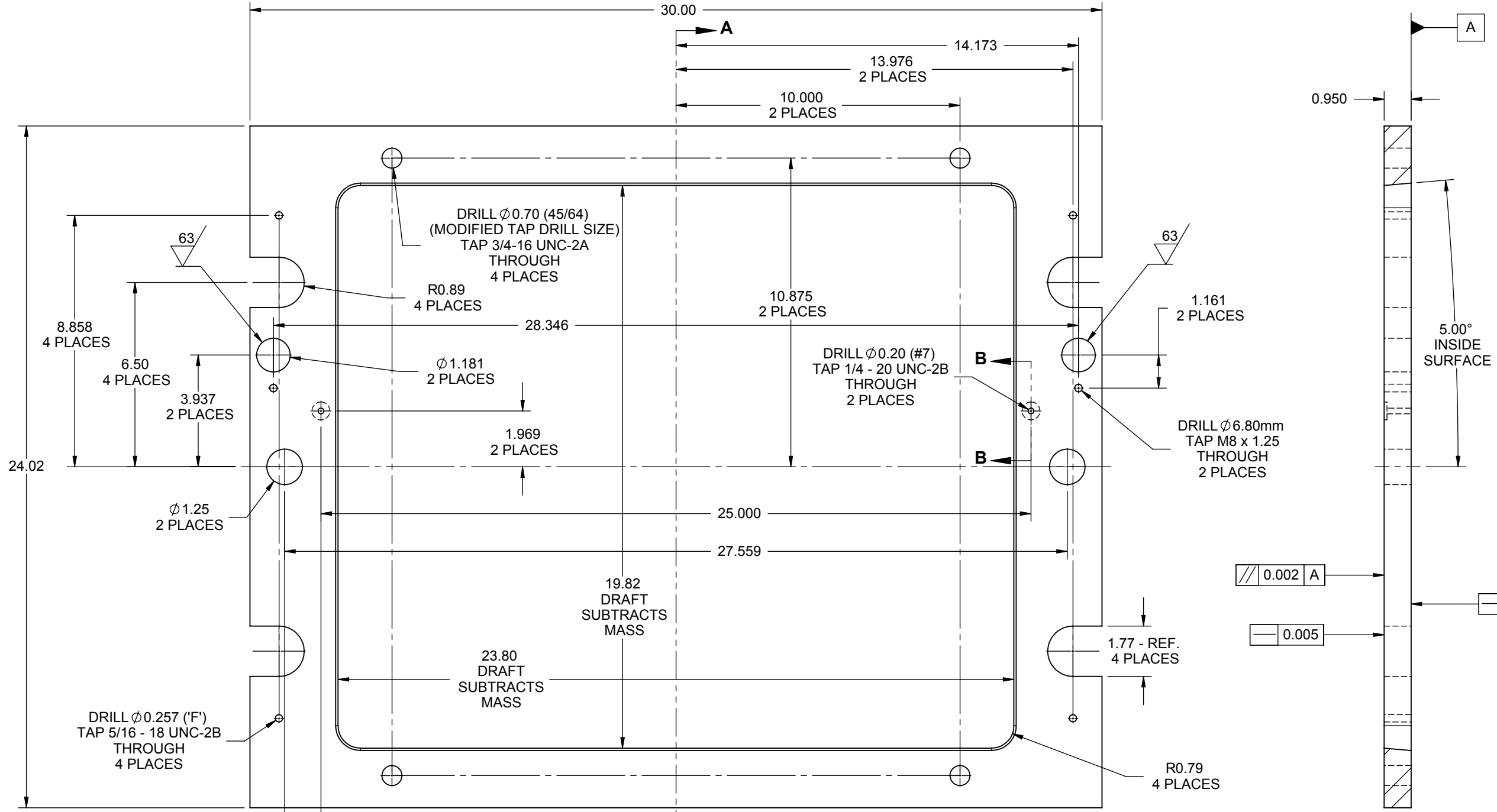

UNLESS OTHERWISE SPECIFIED DIMENSIONS ARE IN INCHES		THE INFORMATION CONTAINED IN THIS DRAWING IS THE SOLE PROPERTY OF GARTLAND FOUNDRY, INC. ANY REPRODUCTION IN PART OR WHOLE WITHOUT THE WRITTEN PERMISSION OF FRESNO VALVES & CASTINGS INC. IS PROHIBITED	
TITLE	DATE	NAME	
DRAWN	08/21/08	KTO	
CHECKED			
APPRVD			
TOLERANCE ARE: FRACTIONAL DIM. $\pm 1/16"$ ANGULAR DIM. $\pm 0.50"$ CASTING DIM. $\pm 0.025"$ UPTO 6" ADD $\pm 0.0025"$ / INCH OVER 6" MACHINE DIM. $\pm 0.100"$ X.X" MACHINE DIM. $\pm 0.010"$ X.XX" MACHINE DIM. $\pm 0.005"$ X.XXX" BENDS DIM. $\pm 1/2"$		GARTLAND FOUNDRY, INC. P.O. BOX 2008, TERRE HAUTE, IN 47808 PHONE (812) 232-0226, FAX. (812) 232-7569	
DEBURR ALL SHARP EDGES & CORNERS ON CASTINGS MACH. PARTS, SHT. METAL PARTS		DIVISION: FOUNDRY	
MATERIAL : AISI 1020		MASTER FRAME 20x24	
TYPE :		SCALE: NTS WEIGHT: 61.55 lbs SHEET 1 OF 1	
		DRAWING NO. FBOIII-00-010	